



## INSTALLING THE LAPS SENSOR

Chain counter installation takes place in three steps: installation of the laps sensor on the windlass, mounting of the chain counter and electrical connections.

### Quick® windlasses

All Quick® windlasses come with a laps sensor suitable for use with chain counter CHC 1102 M.

### Other windlasses

In order for the chain counter to measure the exact length of the chain, it has to count the number of revolutions completed by the gear that drives the chain (gypsy). A laps sensor kit is supplied with the chain counter. This kit includes a cylindrical magnet, a magnetic field sensor and two plastic adaptors to be used to secure the sensor in place. The magnet is to be secured to the gypsy while the magnetic sensor is to be fixed to the windlass base.

The standard installation procedure is described below. Unfortunately we cannot describe a procedure applicable to all types of situation. Adapt this procedure to satisfy your own individual requirements.

### EXAMPLES OF LAPS SENSOR INSTALLATION

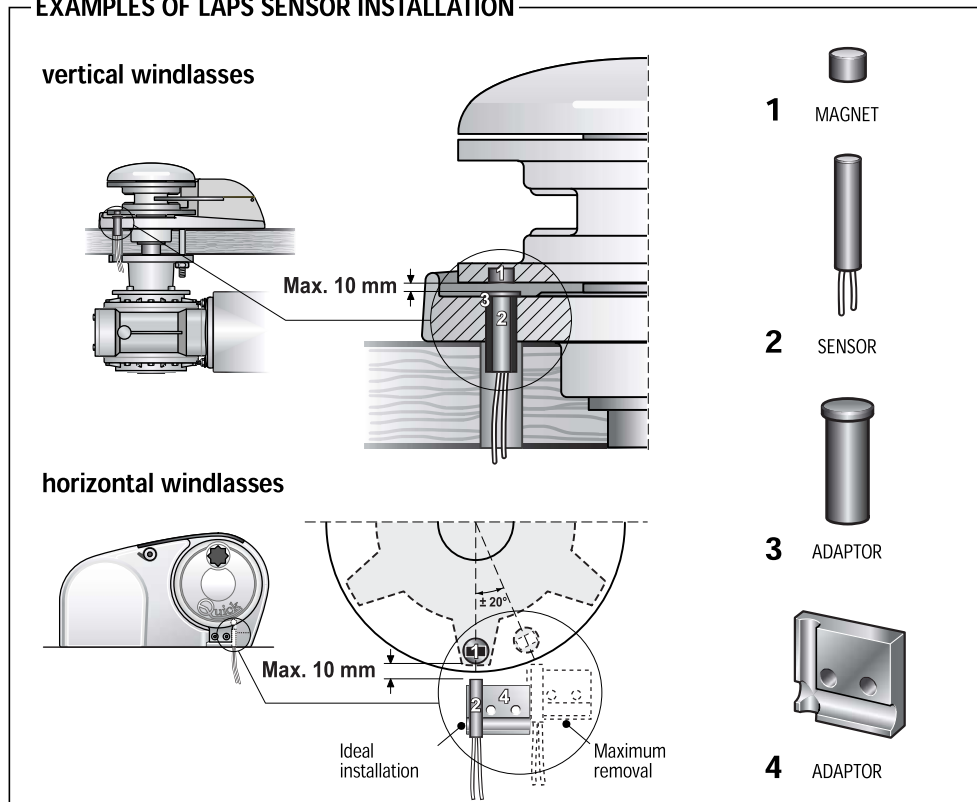



### INSTALLING THE MAGNET

Take the gypsy off the windlass (consult the user's manual that deals with the windlass). Find the spot most suitable for the magnet housing based on the following criteria:

- The magnet should not be installed in an area that the chain passes through (outer areas).
- The location should be preferably made in the area where the gypsy is thickest (in order not to weaken the structure).
- Regarding horizontal windlasses, make sure it is located near the edge of the gypsy.
- Regarding vertical windlasses, make certain the sensor is installed on the base at the circumference "traced" by the magnet.
- The magnet can protrude from the gypsy; make certain it does not interfere with the base or sensor.
- The magnet should be as close to the sensor as possible.

Once the hole has been drilled, glue the magnet inside it. Make sure the glue covers the part of the magnet still visible. Use glue designed for metals, resistant to brackish ambients and capable of withstanding temperatures ranging from  $-30$  to  $+80$  °C. Generally speaking, epoxy-based bi-component glues satisfy these requirements.

Several magnets can be installed on the same gypsy to increase the precision with which the chain counter reads (not provided). Place any additional magnets around the same circumference equally spaced apart.

### INSTALLING THE SENSOR

Locate the most suitable position to secure the sensor to the base according to the following criteria:

- The sensor should not be installed in an area that the chain passes through.
- If holes are made in the base, make sure they do not interfere with normal operation, do not weaken the structure or cause lubricant to flow out (windlasses with oil-bathed gears).
- Regarding vertical windlasses, make certain the sensor can be installed on the base at the circumference "traced" by the magnet.
- The magnet should be as close to the sensor as possible.

Use the plastic adaptors provided to secure the sensor. Use a sheath to protect the sensor cables.

Once installed, make sure the laps sensor works properly. Place the gypsy so that the magnet is aligned with the sensor and check electrical continuity between the two sensor cables. When the magnet is moved away from the sensor electrical continuity should no longer be present.